

Pressure Booster System

Installation/Operating Manual

Hydro-Unit Single Line

Hydro-Unit Single Line MVP



CE

Legal information/Copyright

Original operating manual Hydro-Unit Single Line

All rights reserved. The contents provided herein must neither be distributed, copied, reproduced, edited or processed for any other purpose, nor otherwise transmitted, published or made available to a third party without the manufacturer's express written consent.

Subject to technical modification without prior notice.

© Duijvelaar Pompen B.V., Alphen aan den Rijn, Netherlands 2025-06-30

Contents

	Glossary.....	5
1	General.....	6
	1.1 Principles	6
	1.2 Software changes	6
	1.3 Installation of partly completed machinery	6
	1.4 Target group	6
	1.5 Other applicable documents	6
	1.6 Symbols	6
	1.7 Key to safety symbols/markings	7
2	Safety	8
	2.1 General	8
	2.2 Intended use	8
	2.2.1 Prevention of foreseeable misuse	8
	2.3 Personnel qualification and personnel training	9
	2.4 Consequences and risks caused by non-compliance with this manual	9
	2.5 Safety awareness	9
	2.6 Safety information for the operator/user	9
	2.7 Safety information for maintenance, inspection and installation	10
	2.8 Unauthorised modes of operation	10
	2.9 Electromagnetic compatibility (EMC)	10
	2.9.1 Interference emission requirements	10
	2.9.2 Line harmonics requirements	11
	2.9.3 Interference immunity requirements	11
3	Transport/Storage/Disposal.....	13
	3.1 Checking the condition upon delivery	13
	3.2 Transport.....	13
	3.3 Storage/preservation.....	13
	3.4 Return to supplier.....	14
	3.5 Disposal	14
4	Description	15
	4.1 General description	15
	4.2 Product information as per Regulation No. 1907/2006 (REACH)	15
	4.3 Description	15
	4.4 Name plate.....	15
	4.5 Design details	16
	4.6 Configuration and function	17
	4.7 Noise characteristics	17
	4.8 Scope of supply	17
	4.8.1 Inlet conditions, version M	18
	4.8.2 Inlet conditions, version F	19
	4.8.3 Inlet conditions, version L	20
	4.9 Dimensions	21
	4.10 Terminal wiring diagram.....	21
	4.11 Potential equalisation	21
5	Installation at Site	22
	5.1 Checks to be carried out prior to installation	22
	5.2 Installing the pressure booster system	23



5.3	Connecting the piping	23
5.3.1	Fitting an expansion joint (optional).....	23
5.3.2	Fitting the pressure reducer (optional).....	24
5.4	Mounting the accumulator.....	24
5.5	Connecting the dry running protection device.....	25
5.6	Electrical connection	25
5.6.1	Sizing the power cable	26
5.6.2	Connecting the pressure booster system.....	26
6	Commissioning/Start-up/Shutdown.....	27
6.1	Commissioning/Start-up.....	27
6.1.1	Prerequisites for commissioning/start-up	27
6.1.2	Dry running protection	27
6.1.3	Commissioning/start-up of pressure booster system	27
6.2	Operating limits	29
6.2.1	Frequency of starts.....	29
6.2.2	Ambient conditions	29
6.2.3	Maximum operating pressure	29
6.2.4	Fluid handled.....	29
6.2.5	Minimum flow rate	30
6.3	Switching on the pressure booster system	30
6.4	Checklist for commissioning/start-up	30
6.5	Shutdown	31
6.5.1	Shutdown.....	31
6.5.2	Measures to be taken for shutdown	31
7	Operating the Pressure Booster System.....	32
7.1	Design of the frequency inverter	32
7.1.1	Display of the frequency inverter, start view.....	33
7.2	Pressure booster systems with configured frequency inverter drives	34
7.3	Programming	34
8	Servicing/Maintenance	36
8.1	General information/Safety regulations.....	36
8.1.1	Inspection contract	37
8.2	Servicing/inspection	37
8.2.1	Supervision of operation.....	37
8.2.2	Maintenance schedule.....	37
8.2.3	Setting the pre-charge pressure	38
8.2.4	Replacing the non-return valve.....	39
9	Trouble-shooting	42
10	Related Documents	44
10.1	General assembly drawings/exploded views with list of components.....	44
10.1.1	Hydro-Unit Single Line MVP.....	44
11	EU Declaration of Conformity.....	45
12	Certificate of Decontamination.....	46
13	Commissioning Report	47
	Index.....	48

Glossary

Accumulator

Pressure losses may occur in the piping downstream of the pressure booster system as a result of losses due to leakage. The accumulator serves to compensate for pressure losses and minimises the frequency of starts of the pressure booster system.

Certificate of decontamination

A certificate of decontamination is enclosed by the customer when returning the product to the manufacturer to certify that the product has been properly drained to eliminate any environmental and health hazards arising from components in contact with the fluid handled.

Dry running protection

Dry running protection devices prevent the pump from being operated without the fluid to be handled, which would result in pump damage.

IE3

Efficiency class to IEC 60034-30: 3 = Premium Efficiency (IE = International Efficiency)

Manual mode

Direct operation on the power supply network, independently of the control unit.

Switchgear and controlgear assembly

Control cabinet with one or several control units / switchgears and electrical equipment.

1 General

1.1 Principles

This operating manual is valid for the type series and variants indicated on the front cover.

The operating manual describes the proper and safe use of this equipment in all phases of operation.

The name plate indicates the type series, the main operating data and the serial number. The serial number uniquely describes the product and is used as identification in all further business processes.

In the event of damage, immediately contact your nearest Duijvelaar Pompen B.V. service facility to maintain the right to claim under warranty.

1.2 Software changes

The software has been specially created for this product and thoroughly tested. Making changes or additions to the software or parts of the software is prohibited. This does not, however, apply to software updates by Duijvelaar Pompen B.V..

1.3 Installation of partly completed machinery

To install partly completed machinery supplied by Duijvelaar Pompen B.V. refer to the subsections under Servicing/Maintenance.

1.4 Target group

This operating manual is aimed at the target group of trained and qualified specialist technical personnel. [⇒ Section 2.3, Page 9]

1.5 Other applicable documents

Table 1: Overview of other applicable documents

Document	Contents
Sub-supplier product literature	Operating manuals, circuit diagram and other product literature describing accessories and integrated machinery components







1.6 Symbols

Table 2: Symbols used in this manual

Symbol	Description
✓	Conditions which need to be fulfilled before proceeding with the step-by-step instructions
▷	Safety instructions
⇒	Result of an action
⇔	Cross-references
1. 2.	Step-by-step instructions
	Note Recommendations and important information on how to handle the product

1.7 Key to safety symbols/markings

Table 3: Definition of safety symbols/markings

Symbol	Description
 DANGER	DANGER This signal word indicates a high-risk hazard which, if not avoided, will result in death or serious injury.
 WARNING	WARNING This signal word indicates a medium-risk hazard which, if not avoided, could result in death or serious injury.
 CAUTION	CAUTION This signal word indicates a hazard which, if not avoided, could result in damage to the machine and its functions.
	General hazard In conjunction with one of the signal words this symbol indicates a hazard which will or could result in death or serious injury.
	Electrical hazard In conjunction with one of the signal words this symbol indicates a hazard involving electrical voltage and identifies information about protection against electrical voltage.
	Machine damage In conjunction with the signal word CAUTION this symbol indicates a hazard for the machine and its functions.

2 Safety



All the information contained in this section refers to hazardous situations.

In addition to the present general safety information the action-related safety information given in the other sections must be observed.

2.1 General

- This operating manual contains general installation, operating and maintenance instructions that must be observed to ensure safe operation of the system and prevent personal injury and damage to property.
- Comply with all the safety instructions given in the individual sections of this operating manual.
- The operating manual must be read and understood by the responsible specialist personnel/operators prior to installation and commissioning.
- The contents of this operating manual must be available to the specialist personnel at the site at all times.
- Information and markings attached directly to the product must always be complied with and kept in a perfectly legible condition at all times. This applies to, for example:
 - Arrow indicating the direction of rotation
 - Markings for connections
 - Name plate
- The operator is responsible for ensuring compliance with all local regulations not taken into account.

2.2 Intended use

- The pressure booster system must only be operated within the operating limits described in the other applicable documents.
- Only operate pressure booster systems which are in perfect technical condition.
- Do not operate partially assembled pressure booster systems.
- The pressure booster system must only handle the fluids described in the product literature of the respective design variant.
- Never operate the pressure booster system without the fluid to be handled.
- Observe the information on minimum flow rates specified in the product literature (to prevent overheating, bearing damage, etc).
- Observe the maximum flow rates indicated in the data sheet or product literature (to prevent overheating, cavitation damage, bearing damage, etc).
- Do not throttle the flow rate on the suction side of the pressure booster system (to prevent cavitation damage).
- Consult the manufacturer about any other modes of operation not described in the product literature.

2.2.1 Prevention of foreseeable misuse

- Never exceed the permissible application and operating limits specified in the data sheet or product literature regarding temperature, etc.
- Observe all safety information and instructions in this manual.

2.3 Personnel qualification and personnel training

- All personnel involved must be fully qualified to install, operate, maintain and inspect the product this manual refers to.
- The responsibilities, competence and supervision of all personnel involved in transport, installation, operation, maintenance and inspection must be clearly defined by the operator.
- Deficits in knowledge must be rectified by means of training and instruction provided by sufficiently trained specialist personnel. If required, the operator can commission the manufacturer/supplier to train the personnel.
- Training on the pressure booster system must always be supervised by specialist technical personnel.

2.4 Consequences and risks caused by non-compliance with this manual

- Non-compliance with these operating instructions will lead to forfeiture of warranty cover and of any and all rights to claims for damages.
- Non-compliance can, for example, have the following consequences:
 - Hazards to persons due to electrical, thermal, mechanical and chemical effects and explosions
 - Failure of important product functions
 - Failure of prescribed maintenance and servicing practices
 - Hazard to the environment due to leakage of hazardous substances

2.5 Safety awareness

In addition to the safety information contained in this operating manual and the intended use, the following safety regulations shall be complied with:

- Accident prevention, health regulations and safety regulations
- Explosion protection regulations
- Safety regulations for handling hazardous substances
- Applicable standards, directives and laws

2.6 Safety information for the operator/user

- Fit protective equipment (e.g. contact guards) supplied by the operator for hot, cold or moving parts, and check that the equipment functions properly.
- Do not remove any protective equipment (e.g. contact guards) during operation.
- Eliminate all electrical hazards. (In this respect refer to the applicable national safety regulations and/or regulations issued by the local energy supply companies.)
- If stopping the pump does not increase potential risk, fit an emergency-stop control device in the immediate vicinity of the pump (set) during pump set installation.

2.7 Safety information for maintenance, inspection and installation

- Modifications or alterations of the pressure booster system are only permitted with the manufacturer's prior consent.
- Use only original spare parts or parts authorised by the manufacturer. The use of other parts can invalidate any liability of the manufacturer for resulting damage.
- The operator ensures that maintenance, inspection and installation are performed by authorised, qualified specialist personnel who are thoroughly familiar with the manual.
- Carry out work on the pressure booster system during standstill only.
- The pump casing must have cooled down to ambient temperature.
- Pump pressure must have been released and the pump must have been drained.
- When taking the pressure booster system out of service always adhere to the procedure described in the manual.
- Decontaminate pressure booster systems which handle fluids posing a health hazard.
- As soon as the work has been completed, re-install and/or re-activate any safety-relevant and protective devices. Before returning the product to service, observe all instructions on commissioning.
- Make sure the pressure booster system cannot be accessed by unauthorised persons (e.g. children).
- Prior to opening the device, pull the mains plug and wait for at least 10 minutes.

2.8 Unauthorised modes of operation

Always observe the limits stated in the product literature.

The warranty relating to the operating reliability and safety of the pressure booster system supplied is only valid if the equipment is used in accordance with its intended use.

[⇒ Section 2.2, Page 8]

2.9 Electromagnetic compatibility (EMC)

2.9.1 Interference emission requirements

The EN 61800-3 EMC product standard is relevant for electric variable speed drives/control systems. It specifies all pertinent requirements and refers to the relevant generic standards for complying with the EMC Directive.

Frequency inverters are commonly used by operators as a part of a system, plant or machine assembly. It should be noted that the operator bears all responsibility for the final EMC properties of the equipment, plant or installation.

A prerequisite or requirement for complying with the relevant standards or the limit values and inspection/test levels referenced by them is that all information and descriptions regarding EMC-compliant installation be observed and followed.

In accordance with the EMC product standard, the EMC requirements to be met depend on the purpose or intended use of the frequency inverter. Four categories are defined in the EMC product standard:

Table 4: Categories of intended use

Category	Definition	Limits to EN 55011
C1	Frequency inverters with a supply voltage under 1000 V installed in the first environment (residential and office areas).	Class B
C2	Frequency inverters with a supply voltage under 1000 V installed in the first environment (residential and office areas) that are neither ready to be plugged in/connected nor are mobile and must be installed and commissioned by specialist personnel.	Class A, Group 1
C3	Frequency inverters with a supply voltage under 1000 V installed in the second environment (industrial environments).	Class A, Group 2
C4	Frequency inverters with a supply voltage over 1000 V and a nominal current over 400 A installed in the second environment (industrial environments) or that are envisaged for use in complex systems.	No borderline/boundary ¹⁾

The following limit values and inspection/test levels must be complied with if the generic standard on interference emissions applies:

Table 5: Classification of installation environment

Environment	Generic standard	Limits to EN 55011
First environment (residential and office areas)	EN/IEC 61000-6-3 for private, business and commercial environments	Class B
Second environment (industrial environments)	EN/IEC 61000-6-4 for industrial environments	Class A, Group 1

The frequency inverter meets the following requirements:

Table 6: EMC properties of the frequency inverter

Power [kW]	Cable length [m]	Category to EN 61800-3	Limits to EN 55011
≤ 11	≤ 5	C1	Class B

The EN 61800-3 standard requires that the following warning be provided for drive systems that do not comply with category C1 specifications:

This product can produce high-frequency interference emissions that may necessitate targeted interference suppression measures in a residential or office environment.

2.9.2 Line harmonics requirements

The product is a device for professional applications as defined by EN 61000-3-2. The following generic standards apply when establishing a connection to the public power grid:

- EN 61000-3-2 for symmetric, three-phase devices (professional devices with a total power of up to 1 kW)
- EN 61000-3-12 for devices with a phase current of between 16 A and 75 A and professional devices from 1 kW up to a phase current of 16 A.

2.9.3 Interference immunity requirements

In general, the interference immunity requirements for a frequency inverter hinge on the specific environment in which the inverter is installed.

The requirements for industrial environments are therefore higher than those for residential and office environments.

The frequency inverter is designed such that the immunity requirements for industrial environments and, thus, the lower-level requirements for residential and office environments, are met and fulfilled.

¹ An EMC plan must be devised.

The following relevant generic standards are used for the interference immunity test:

- EN 61000-4-2: Electromagnetic compatibility (EMC)
 - Part 4-2: Testing and measurement techniques – Electrostatic discharge immunity test
- EN 61000-4-3: Electromagnetic compatibility (EMC)
 - Part 4-3: Testing and measurement techniques – Radiated, radio-frequency, electromagnetic field immunity test
- EN 61000-4-4: Electromagnetic compatibility (EMC)
 - Part 4-4: Testing and measurement techniques – Electrical fast transient/burst immunity test
- EN 61000-4-5: Electromagnetic compatibility (EMC)
 - Part 4-5: Testing and measurement techniques – Surge immunity test
- EN 61000-4-6: Electromagnetic compatibility (EMC)
 - Part 4-6: Testing and measurement techniques – Immunity to conducted disturbances, induced by radio-frequency fields

3 Transport/Storage/Disposal

3.1 Checking the condition upon delivery

1. On transfer of goods, check each packaging unit for damage.
2. In the event of in-transit damage, assess the exact damage, document it and notify Duijvelaar Pompen B.V. or the supplying dealer and the insurer about the damage in writing immediately.

3.2 Transport



⚠ DANGER

Pressure booster system tipping over

Danger to life from falling pressure booster system!

- ▷ Never suspend the pressure booster system by its power cable.
- ▷ Do not lift the pressure booster system by its manifold.
- ▷ Observe the applicable local accident prevention regulations.
- ▷ Observe the information on weights, centre of gravity and fastening points.
- ▷ Use suitable and permitted transport equipment, e.g. crane, forklift or pallet jack.

- ✓ Transport equipment / lifting equipment suitable for the corresponding weight has been selected and is on hand.
1. Remove the packaging. Remove the caps from the connection openings.
 2. Check for any in-transit damage.
 3. Transport the pressure booster system to the place of installation.
 4. Detach the pressure booster system from the pallet using a suitable tool.
 5. Separate the pressure booster system from the wooden skids with a suitable tool. Lift the pressure booster system off. Dispose of the wooden skids.
 6. Carefully place down the pressure booster system at the site of installation.

3.3 Storage/preservation



CAUTION

Damage during storage due to frost, moisture, dirt, UV radiation or vermin

Corrosion/contamination of pressure booster system!

- ▷ Store the pressure booster system in a frost-proof room. Do not store outdoors.



CAUTION

Wet, contaminated or damaged openings and connections

Leakage or damage of the pressure booster system!

- ▷ Only open the openings of the pressure booster system at the time of installation.

If commissioning is to take place some time after delivery, we recommend that the following measures be taken:

Store the pressure booster system in a dry, protected room where the atmospheric humidity is as constant as possible.

Table 7: Ambient conditions for storage

Ambient condition	Value
Relative humidity	50 % maximum
Ambient temperature	0 °C to +40 °C

- Frost-free
- Well-ventilated

3.4 Return to supplier

1. Drain the pressure booster system as per operating instructions.
2. Always flush and clean the pressure booster system, particularly if it has been used for handling noxious, explosive, hot or other hazardous fluids.
3. If the pressure booster system has handled fluids whose residues could lead to corrosion damage in the presence of atmospheric humidity or could ignite upon contact with oxygen, the pressure booster system must also be neutralised, and anhydrous inert gas must be blown through the pressure booster system to ensure drying.
4. Always complete and enclose a certificate of decontamination when returning the pressure booster system. [⇒ Section 12, Page 46]
Always indicate any safety and decontamination measures taken.



NOTE

If required, a blank certificate of decontamination can be downloaded from the following web site: www.dp.nl/certificates-of-decontamination

3.5 Disposal



WARNING

Fluids handled, consumables and supplies which are hot and/or pose a health hazard

Hazard to persons and the environment!

- ▷ Collect and properly dispose of flushing fluid and any fluid residues.
- ▷ Wear safety clothing and a protective mask if required.
- ▷ Observe all legal regulations on the disposal of fluids posing a health hazard.

1. Dismantle the pressure booster system.
Collect greases and other lubricants during dismantling.
2. Separate and sort the pump materials, e.g. by:
 - Metals
 - Plastics
 - Electronic waste
 - Greases and other lubricants
3. Dispose of materials in accordance with local regulations or in another controlled manner.

Electrical or electronic equipment marked with the adjacent symbol must not be disposed of in household waste at the end of its service life.

Contact your local waste disposal partner for returns.

If the used electrical or electronic equipment contains personal data, the operator is responsible for deleting it before the equipment is returned.

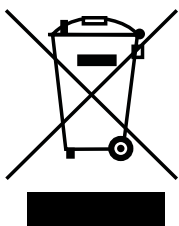

4 Description

4.1 General description

- Pressure booster system

4.2 Product information as per Regulation No. 1907/2006 (REACH)

For information as per chemicals Regulation (EC) No. 1907/2006 (REACH), see <https://www.dp.nl/reach>.

4.3 Description

Example: HU1 Single Line DPV 10/4 B MVP

Table 8: Designation key

Code	Description
HU	Hydro-Unit
1	Number of pumps
Single Line	Type series
DPV 10	Size
	DPV 10
4 B	Number of stages
MVP	Design
	MVP
	Variable speed pressure booster system

4.4 Name plate

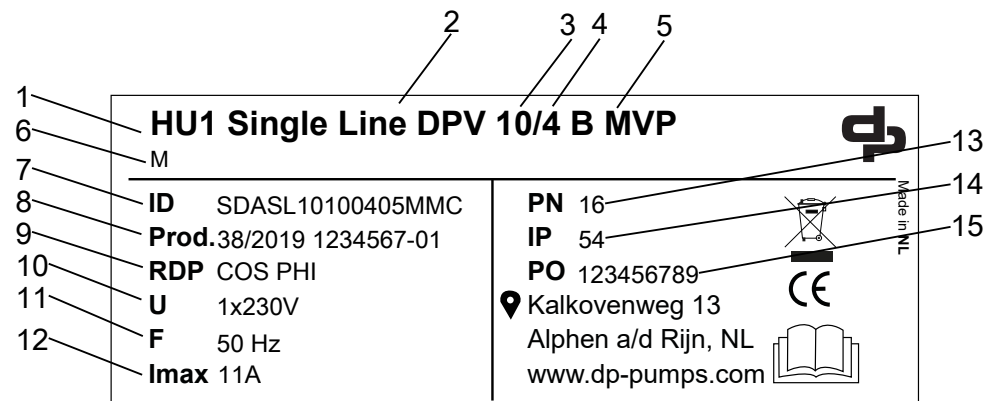

Fig. 1: Name plate (example)

1	Number of pumps	9	Dry running protection
2	Type series	10	Power supply voltage
3	Size	11	Power supply frequency
4	Number of stages	12	Maximum current input
5	Design	13	Max. operating pressure

6	Inlet conditions ²⁾	14	Enclosure
7	Serial number	15	Order number
8	Month of production / year of production, consecutive number		

4.5 Design details

- Fully automatic pressure booster system
- Variable speed operation
- Baseplate-mounted
- Hydraulic components made of stainless steel / brass
- Check valve
- Discharge-side, direct-flow membrane-type accumulator, approved for drinking water
- Pressure gauge
- Electronic dry running protection
- Pressure transmitter on the discharge side

Installation

- Stationary dry installation

Drive

- Electric motor
- Efficiency class IE3 to IEC 60034-30
- Enclosure IP55

²⁾ M = Inlet side of pressure booster system connected to the municipal water supply, suction head operation, F = Pressure booster system with break tank arranged on same level as pump, suction head operation, L = Pressure booster system with break tank arranged at a lower level, suction lift operation

4.6 Configuration and function



Fig. 2: Illustration of the pressure booster system

1	Pump
2	Control system
3	Membrane-type accumulator
4	Manifold
5	Baseplate

Design The fully automatic pressure booster system is equipped with 1 vertical high-pressure pump (1) (variable speed) for pumping the fluid handled to the consumer installations in the set pressure range.

Function Automatic mode One pump (1) is controlled and monitored by a motor-mounted frequency inverter.

The standard setting is for the pressure booster system to start automatically as a function of pressure; the actual pressure is measured by an analog pressure transmitter. The use of this variable speed pump significantly reduces wear as well as the frequency of pump starts in parallel operation.

If a duty pump fails, a fault is output, which can be reported via volt-free contacts (e.g. to the control station).

If the demand drops towards 0, the pressure booster system slowly runs down to the stop point and stops.

The pressure booster system is designed with dry running protection.

If a pump has not been in operation for 24 hours, a test run is initiated for this pump.

Function Manual mode In manual mode, a minimum flow is required to protect the pump against overheating.

4.7 Noise characteristics

For the noise characteristics refer to the operating manual of the pump (set).

4.8 Scope of supply

Depending on the model, the following items are included in the scope of supply:

Pressure booster system

- 1 vertical high-pressure centrifugal pump with oval flange
- Powder-coated / epoxy resin-coated steel baseplate
- Integrated check valve
- Pressure transmitter on the discharge side
- Pressure gauge
- Discharge-side, direct-flow membrane-type accumulator, approved for drinking water

Control unit

- Single-phase frequency inverter, motor-mounted

4.8.1 Inlet conditions, version M

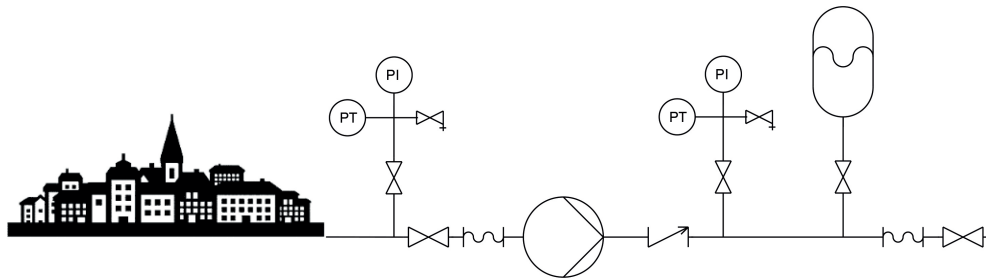

Fig. 3: M = Inlet side of pressure booster system connected to the municipal water supply, suction head operation

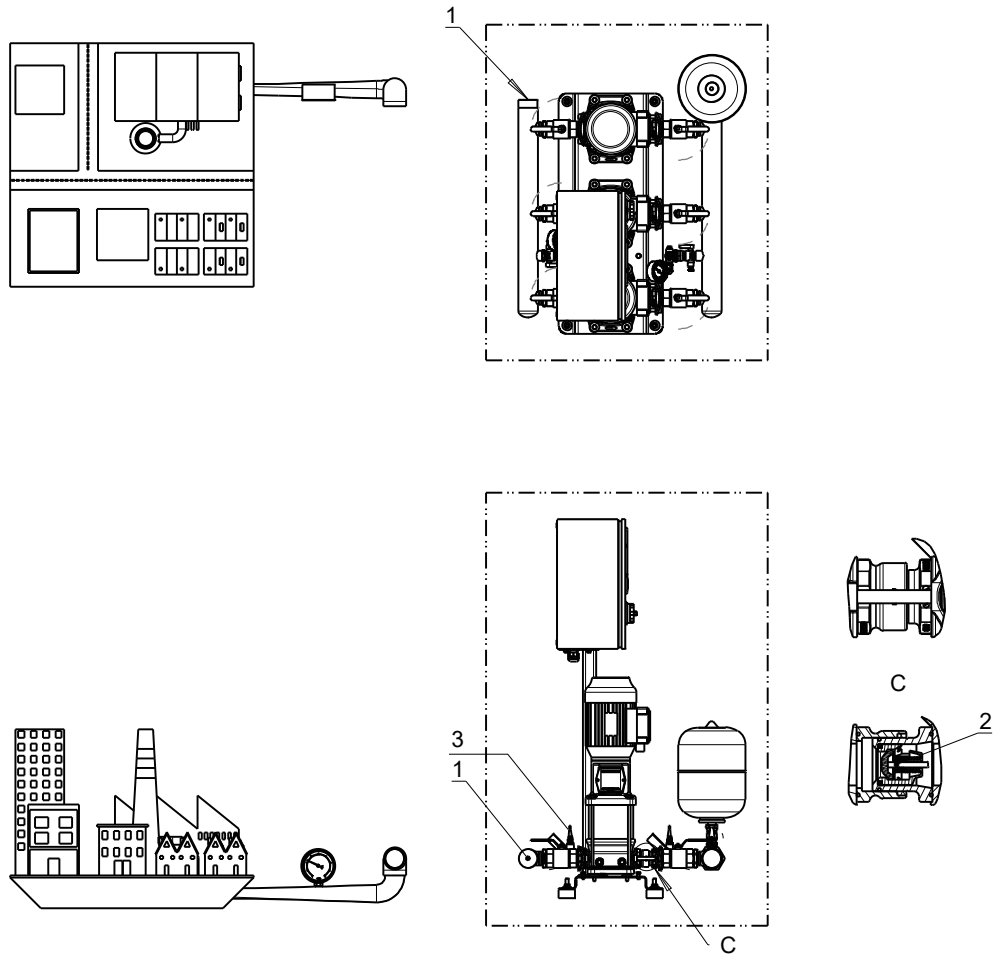

Fig. 4: Scope of supply for version M

1	Suction line (included in Duijvelaar Pompen B.V.'s scope of supply)
2	Lift check valve (included in Duijvelaar Pompen B.V.'s scope of supply)
3	Dry running protection (included in Duijvelaar Pompen B.V.'s scope of supply)

4.8.2 Inlet conditions, version F

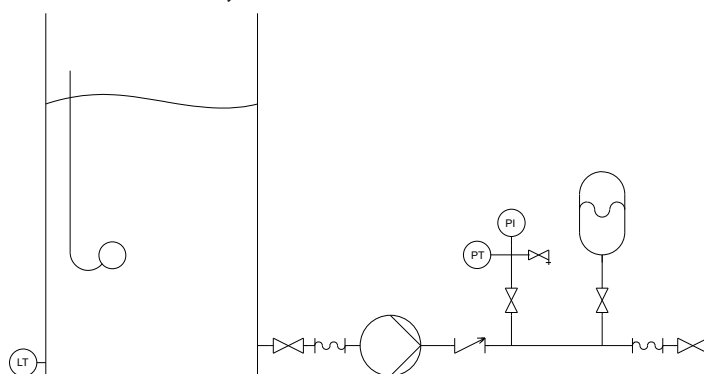

Fig. 5: F = Pressure booster system with break tank arranged on same level as pump, suction head operation

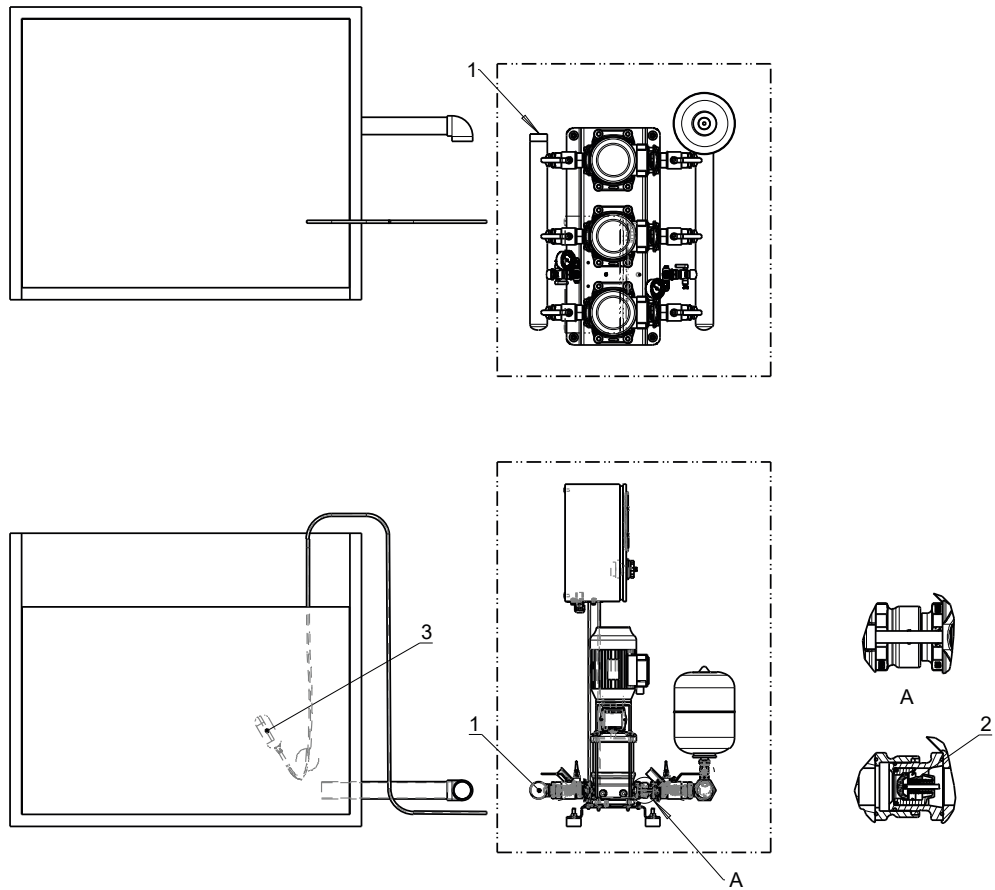

Fig. 6: Scope of supply, version F

1	Suction line (included in Duijvelaar Pompen B.V.'s scope of supply)
2	Lift check valve (included in Duijvelaar Pompen B.V.'s scope of supply)
3	Dry running protection (not included in Duijvelaar Pompen B.V.'s scope of supply)

4.8.3 Inlet conditions, version L

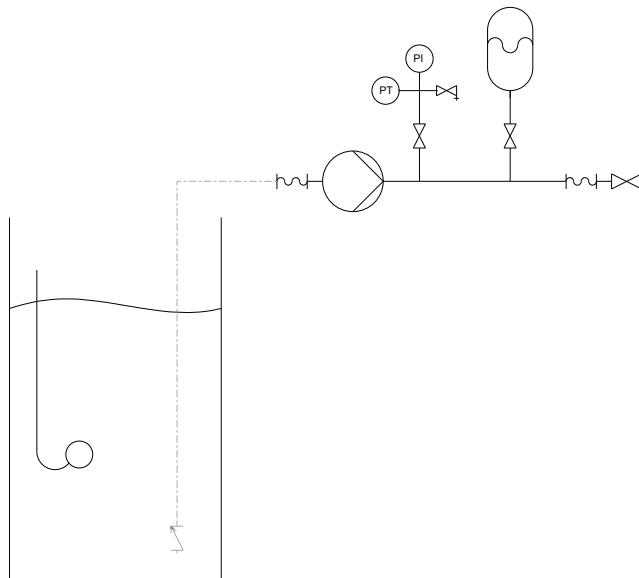

Fig. 7: L = Pressure booster system with break tank arranged at a lower level, suction lift operation

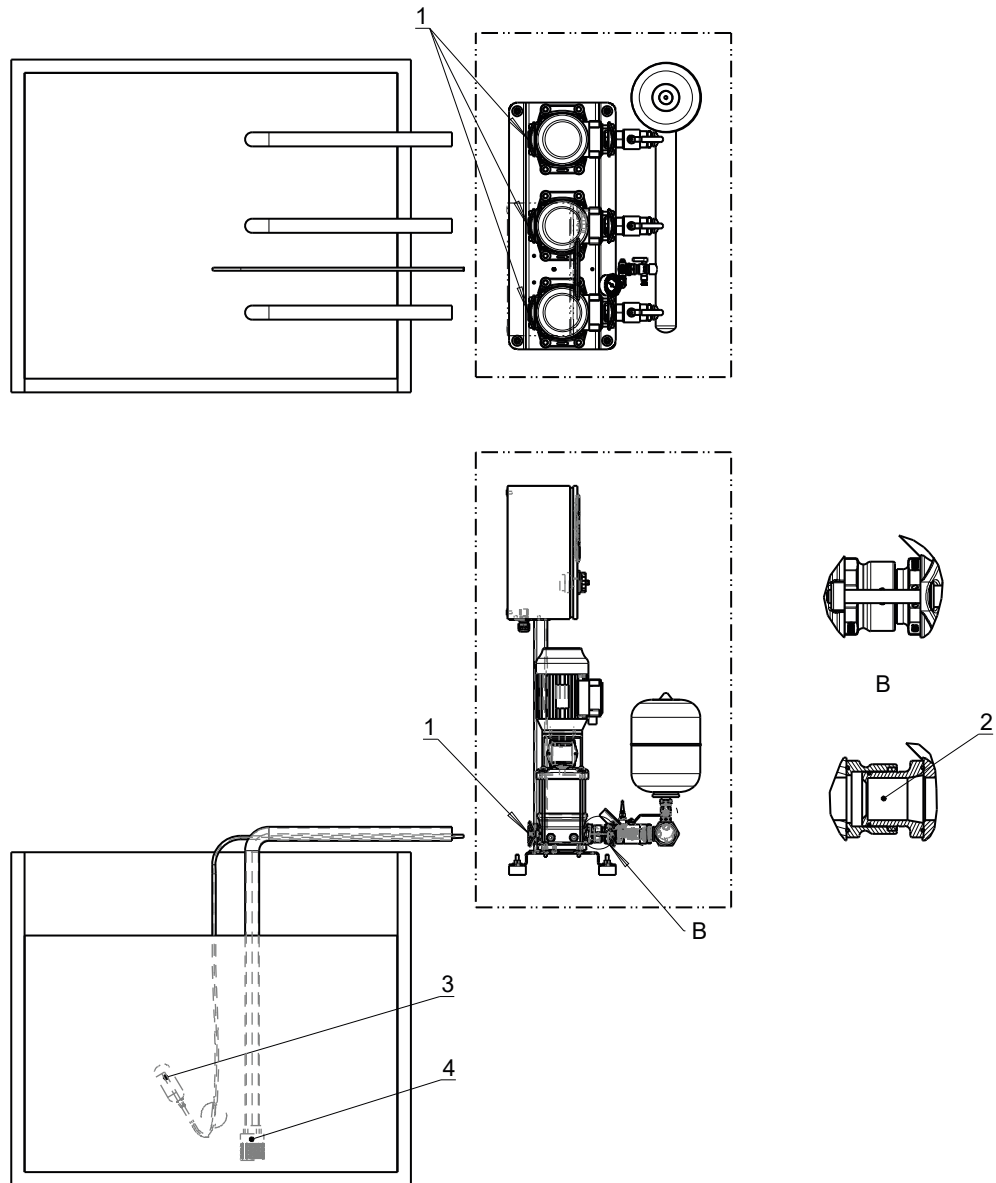

Fig. 8: Scope of supply, version L

1	Suction line (not included in Duijvelaar Pompen B.V.'s scope of supply)
2	Lift check valve (not included in Duijvelaar Pompen B.V.'s scope of supply)
3	Dry running protection (not included in Duijvelaar Pompen B.V.'s scope of supply)
4	Foot valve (not included in Duijvelaar Pompen B.V.'s scope of supply)

4.9 Dimensions

For dimensions refer to the outline drawings of the pressure booster system.

4.10 Terminal wiring diagram

For the terminal assignment refer to the circuit diagram.

4.11 Potential equalisation

The power cable has an earthed plug for potential equalisation.

5 Installation at Site

5.1 Checks to be carried out prior to installation



WARNING

Installation on a mounting surface which is unsecured and cannot support the load

Personal injury and damage to property!

- ▷ Use a concrete of compressive strength class C12/15 which meets the requirements of exposure class X0 to EN 206 .
- ▷ The mounting surface must be set, even, and level.
- ▷ Observe the weights indicated.



NOTE

The anti-vibration mounts of the pressure booster system provide adequate insulation against solid-borne noise.

Thanks to level-adjustable feet (KSB accessory) the pressure booster system can also be installed in a horizontal position on uneven floors.

For pressure booster systems with DPV 2, 4, 6, 10, 15, level-adjustable feet are available as accessories.



NOTE

Do not install pressure booster systems next to sleeping or living quarters.



NOTE

The installation room must provide for suitable drainage.

Before beginning with the installation check the following:

- All structural work required has been checked and prepared in accordance with the dimensions in the outline drawing.
- The data on the name plate of the pressure booster system has been checked. The pressure booster system must be suitable for operation on the available power supply network.
- The place of installation is frost-free.
- The place of installation can be locked.
- The place of installation is well-ventilated.
- A suitably dimensioned drain connection (e.g. leading to a sewer) is available.
- If expansion joints are used, take note of their creep resistance. Expansion joints must be easily replaceable.

The pressure booster system is designed for a maximum ambient temperature of 0 °C to +40 °C at a relative humidity of 60 %.

5.2 Installing the pressure booster system



WARNING

Top-heavy pressure booster system

Risk of personal injury by pressure booster system tipping over!

- Pressure booster systems awaiting final installation must be secured against tipping over.
- Firmly anchor the pressure booster system.



NOTE

To prevent the transmission of piping forces and solid-borne noise, installing expansion joints with length-limiters is recommended.

- ✓ The pressure booster system's packaging has been removed.
 - ✓ A suitable installation site has been selected that meets the requirements.
 - ✓ Sufficient clearance in all directions is provided for servicing work.
1. Make sure that there is sufficient space for the pressure booster system.
 2. Place the pressure booster system in its correct installation position.

5.3 Connecting the piping



CAUTION

Air pockets in suction line

Pressure booster system cannot prime!

- Lay the pipe with a continuously rising slope.

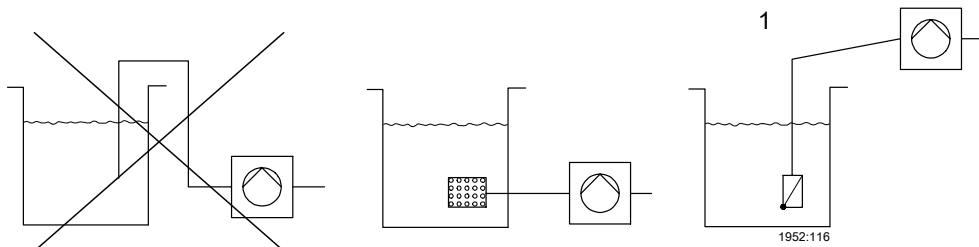

Fig. 9: Correct piping connection

1 | Suction lift operation

1. Mechanically support the suction head line on site to provide for absorption of mechanical forces.
2. Install the piping without transmitting any stresses and strains.
3. Connect the piping to the distribution lines on the inlet side and discharge side.

5.3.1 Fitting an expansion joint (optional)



DANGER

Sparks and radiant heat

Fire hazard!

- Take suitable precautions to protect the expansion joint if any welding work is carried out.



CAUTION

Leaking expansion joint

Flooding of installation room!

- ▷ Never use the expansion joint to compensate for misalignment or mismatch of the piping.
- ▷ Do not apply any paint to the expansion joint.
- ▷ Keep the expansion joint clean.
- ▷ Regularly check for cracks or blisters, exposed fabric or other defects.

- ✓ Sufficient clearance in all directions is provided for checking the expansion joint.
 - ✓ The expansion joint is not insulated along with the pipeline insulation.
1. Sufficient clearance in all directions is provided for checking the expansion joint.
 2. Install the expansion joint in the piping free of twist or distortion.
 3. Evenly tighten the bolts crosswise. The ends of the bolts must not protrude from the flange.

5.3.2 Fitting the pressure reducer (optional)



NOTE

A pipe length of approximately 600 mm must be provided on the inlet side to accommodate a pressure reducer, if necessary.



NOTE

A pressure reducer must be installed if the inlet pressure fluctuation is too high for the pressure booster system to operate as intended or if the total pressure (inlet pressure and shut-off head) exceeds the design pressure.

The inlet pressure (p_{inl}) varies between 4 and 8 bar. A minimum pressure gradient of 5 m is required for the pressure reducer to function properly. This means that the pressure reducer must be mounted 5 m higher than the pressure booster system. The pressure drops by about 0.1 bar per metre of height difference. Alternatively, the pressure reducer can be subjected to a pressure of 0.5 bar.

Example $p_{inl} = 4$ bar

Minimum pressure gradient = 5 m \pm 0.5 bar

Downstream pressure: 4 bar - 0.5 bar = 3.5 bar.

- ✓ A minimum pressure gradient of 5 m is available.
1. Install the pressure reducer in the pipe on the inlet side.

5.4 Mounting the accumulator



CAUTION

Dirt in the pressure booster system

Damage to the pump sets!

- ▷ Clean the accumulator before filling it.

- ✓ The original operating manual of the pressure booster system is on hand.
1. Mechanically and electrically connect the accumulator in accordance with the original operating manual supplied.

5.5 Connecting the dry running protection device

- ✓ The original operating manual of the dry running protection device is on hand.
- 1. Fit the dry running protection device in accordance with the supplied original operating manual. Connect it in the control unit in accordance with the supplied original operating manual.

5.6 Electrical connection

**⚠ DANGER**
Electrical connection work by unqualified personnel
Danger of death from electric shock!

- Always have the electrical connections installed by a trained and qualified electrician.
- Observe regulations IEC 60364 .

**⚠ WARNING**
Incorrect connection to the mains
Damage to the power supply network, short circuit!

- Observe the technical specifications of the local energy supply companies.

**NOTE**
Installing a motor protection device is recommended.

**NOTE**
If a residual current device is installed, observe the operating manual for the frequency inverter.

Lightning protection

- Electrical installations must be protected against overvoltage (binding since 14 December 2018) (see DIN VDE 0100-443 (IEC 60364-4-44:2007/A1:2015, modified) and DIN VDE 0100-534 (IEC 60364-5-53:2001/A2:2015, modified)). Whenever modifications are made to existing installations, retrofitting a surge protective device (SPD) in accordance with VDE is mandatory.
- A maximum cable length of 10 metres should not be exceeded between the surge protective device (usually type 1, internal lightning protection) installed at the service entrance and the equipment to be protected. For longer cables, additional surge protective devices (type 2) must be provided in the sub-distribution board upstream of the equipment to be protected or directly in the equipment itself.
- The associated lightning protection concept must be provided by the operator or by a suitable provider commissioned by the operator. Surge protective devices can be offered for the control units on request.

Wiring diagram

The wiring diagrams are located in the control cabinet, which is where they must be stored. The product literature of the switchgear and controlgear assembly supplied with the system includes a list of the electrical components installed. When ordering spare parts for electrical components, always indicate the number of the wiring diagram.

Terminal assignment

For the terminal assignment refer to the wiring diagram.

5.6.1 Sizing the power cable

1. Determine the cross-section of the power cable based on the total rated power required.

5.6.2 Connecting the pressure booster system

Plug the mains plug into a suitable socket. Observe the data on the name plate.

6 Commissioning/Start-up/Shutdown

6.1 Commissioning/Start-up

6.1.1 Prerequisites for commissioning/start-up



CAUTION

Pump set running dry

Damage to the pump set/pressure booster system!

- Use dry running protection. If the dry running protection terminal is disabled by means of a bridge, the operator shall assume responsibility for any dry running that might occur.

Ensure that the following requirements are met prior to commissioning/start-up :

- The pressure booster system has been flushed and disinfected in accordance with local requirements.
- The pressure booster system has been properly connected to the electric power supply and is equipped with all protection devices.
- All relevant VDE standards and/or regulations applicable in the country of use are complied with.
- The dry running protection device has been installed. [⇒ Section 5.5, Page 25]

6.1.2 Dry running protection

Pressure booster systems are fitted with a dry running protection device.

A float switch whose volt-free contact closes the circuit in upper float position can be connected to the control system as dry running protection. Follow the float switch manufacturer's instructions on how to set the float switch levels.

6.1.3 Commissioning/start-up of pressure booster system



NOTE

Prior to its delivery, the pressure booster system will be tested hydraulically with water and then drained again. For technical reasons the presence of some residual water is unavoidable.

Prior to commissioning/start-up observe EN 806. After prolonged standstill periods, flushing or professional disinfection is recommended. For extensive or branched piping systems, flushing the pressure booster system can be restricted to a limited area.



CAUTION

Foreign matter in the piping

Damage to the pump / pressure booster system!

- Before commissioning/starting up or functional check running the pressure booster system, make sure that there is no foreign matter in the pressure booster system or piping.



NOTE

Commissioning of the pressure booster system - even test running - shall only be carried out in full compliance with all pertinent VDE (German Association of Electrical Engineers) regulations.



CAUTION

Operation without the fluid to be handled

Damage to the pump sets!

- Prime the pressure booster system with the fluid to be handled.

- ✓ The pipe unions between the pump and the piping have been re-tightened.
 - ✓ Flange connections have been firmly tightened.
 - ✓ The cooling air inlet openings and cooling air outlet openings at the motor are unobstructed.
 - ✓ All shut-off valves of the pressure booster system are open.
 - ✓ The pre-charge pressure of the membrane-type accumulator has been checked. [⇒ Section 8.2.3, Page 38]
1. Disconnect the mains plug from the power supply.
 2. Provide connection to power supply.
 3. Open/loosen the vent plugs on the pump (refer to the pump's installation/operating manual).
 4. Slowly open the inlet-side shut-off element and prime the pressure booster system until the fluid to be handled escapes through all vent holes.
 5. Close and slightly tighten the pump vent plugs.
 6. Switch on all motor protection switches.
 7. Set the manual-0-automatic selector switch (if any) to Automatic.
 8. Switch on the master switch.
 9. Open the discharge-side shut-off element.
 10. After the pump set has been run once, switch it off and loosen the vent plugs again to let any remaining air escape.
 11. Tighten the vent plug firmly.
 12. Verify that the pump is running smoothly.
 13. Close the discharge-side shut-off element for a short period in order to verify that the pump reaches the shut-off head.
 14. Close the discharge-side shut-off element, causing the pump to stop.



NOTE

Minor leakage of the mechanical seals during commissioning is normal and will cease after a short period of operation.

6.2 Operating limits



⚠ DANGER

Non-compliance with operating limits

Damage to the pump set!

- Comply with the operating data indicated in the data sheet.
- Avoid operation against a closed shut-off element.
- Never operate the pump set outside the limits specified below.



⚠ DANGER

Non-compliance with operating limits for the fluid handled

Explosion hazard!

- Never use the pump to handle different fluids which might react chemically with each other.
- Never use the pump to handle a flammable fluid with a fluid temperature above the ignition temperature.

6.2.1 Frequency of starts

To prevent high temperature increases in the motor and impermissible loads on the pump, motor, seals and bearings, do not exceed a certain number of starts per hour. See original operating manual of the pump sets.

6.2.2 Ambient conditions

Observe the following parameters and values during operation:

Table 9: Permissible ambient conditions

Ambient condition	Value
Ambient temperature	0 °C to +40 °C
Relative humidity	50 % maximum

6.2.3 Maximum operating pressure



CAUTION

Permissible operating pressure exceeded

Damage to connections and seals!

- Never exceed the operating pressure specified in the data sheet.

The maximum operating pressure equals 16, 25 or 40 bar, depending on the design variant. See name plate.

6.2.4 Fluid handled

6.2.4.1 Permissible fluids to be handled

- Clean fluids not chemically or mechanically aggressive to the pump materials
- Drinking water
- Service water
- Cooling water

6.2.4.2 Fluid temperature

Table 10: Temperature limits of the fluid handled

Permissible fluid temperature	Value
Maximum	+60 °C +25 °C to DIN 1988
Minimum	0 °C

6.2.5 Minimum flow rate

Table 11: Minimum flow rate per pump in manual mode

Size	Minimum flow rate per pump
	[l/h]
DPV 2	200
DPV 4	400
DPV 6	600
DPV 10	1100
DPV 15	1900
DPV 25	2800
DPV 40	4600
DPV 60	6100
DPV 85	8500
DPV 125	12500

6.3 Switching on the pressure booster system

Plug in the mains plug or set the master switch to I to energise the pump.
Readiness for operation is signalled by a permanently lit red LED and a flashing green LED.

6.4 Checklist for commissioning/start-up

Table 12: Checklist

Steps to be carried out	Action	Done
1	Read the operating manual.	
2	Compare the power supply data against the name plate data.	
3	Check the earthing system/take measurements.	
4	Check the mechanical connection to the water mains. Re-tighten the flange and pipe unions.	
5	Prime and vent the pressure booster system from the inlet side.	
6	Check the inlet pressure.	
7	Check whether all cables are firmly connected to the terminals inside the control unit.	
8	Compare the settings of the motor protection switches with the name plate data and re-adjust if necessary.	
9	Check the start-up pressure and the stop pressure; re-adjust if necessary.	
10	Test the proper function of the dry running protection equipment. If not fitted, make a relevant note in the commissioning report.	
11	After the pump sets have been running for 5 to 10 minutes, vent them again.	
12	Set all switches to automatic.	

Steps to be carried out	Action	Done
13	Check the pre-charge pressure.	
14	Enter any deviations from the name plate or order documentation in the commissioning report.	
15	Complete the commissioning report together with the operator/user and instruct the operator/user as to the function of the unit.	

6.5 Shutdown

6.5.1 Shutdown

Standard design

1. Set the master switch to 0.

Additional instruments

1. Set manual-0-automatic selector switch to 0.

6.5.2 Measures to be taken for shutdown

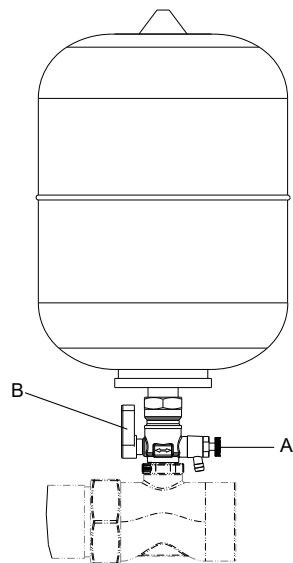

Fig. 10: Venting and draining the accumulator

A	Vent plug
B	Ball valve lever

- ✓ The pressure booster system has been switched off. [⇒ Section 6.5.1, Page 31]
- 1. Turn the ball valve lever B by 45 degrees.
- 2. Open vent plug A at the accumulator.
 - ⇒ The pressure booster system is being vented and drained.
- 3. Close vent plug A at the accumulator.
- 4. Turn the ball valve lever B back into open position (upwards).

7 Operating the Pressure Booster System



CAUTION

Incorrect operation

Water supply is not assured!

- Make sure to comply with all local regulations, particularly the EC Machinery Directive and the EC Directive on Low-Voltage Equipment.

7.1 Design of the frequency inverter



NOTE

An app for connecting with the drive is available to specially trained service staff. The app may be installed via Google Play or App Store.

The frequency inverter is motor-mounted and self-cooling. Its display and control panel feature the following:

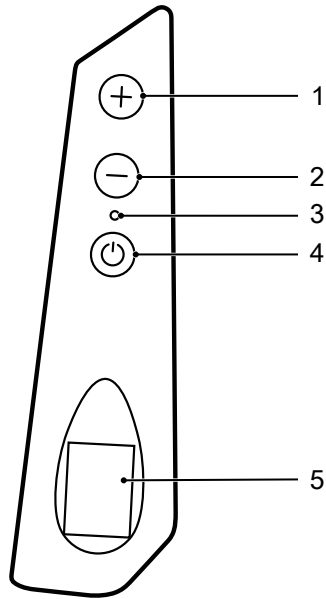

Fig. 11: Buttons and display at the frequency inverter

1	<p>Scrolling through parameters / Adjusting parameter values: The \oplus button can be used to increase the set value or set frequency. To be able to adjust the set value the \oplus or \ominus button has to be pressed for more than 5 seconds until the setting value to be changed starts flashing. To confirm the set value wait for 5 seconds or press the Start/stop button \odot.</p>
2	<p>Scrolling through parameters / Adjusting parameter values: The \ominus button can be used to decrease the set value or set frequency. To be able to adjust the set value the \oplus or \ominus button has to be pressed for more than 5 seconds until the setting value to be changed starts flashing. To confirm the set value wait for 5 seconds or press the Start/stop button \odot.</p>
3	<p>Signal LEDs: Red: The frequency inverter is supplied with the correct supply voltage and is on stand-by. Green: Motor running. Flashing yellow: Alarm condition</p>
4	<p>Start/stop button \odot: Motor start/stop</p>
5	<p>Display:</p> <p>Activating the Start/stop button lock function: Press the Start/stop button \odot for at least 5 seconds. When the Start/stop button lock function is activated, the buttons \oplus and \ominus can be used to scroll through and display the operating parameters. The motor cannot be started or stopped when the Start/stop button lock function is activated.</p> <p>Deactivating the Start/stop button lock function: Press the Start/stop button \odot for at least 5 seconds.</p> <p>Turning the display by 180°: Press the buttons \oplus and \ominus for at least 5 seconds.</p>

7.1.1 Display of the frequency inverter, start view

When the frequency inverter is started up, the control firmware version (LCD=X.XX), the power firmware version (INV =X.XX) and the hardware version (HW =X.XX) are displayed. The start view opens.

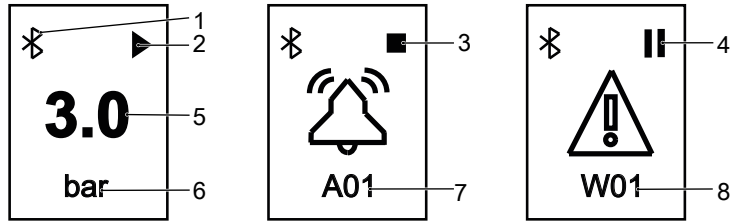

Fig. 12: Display of the frequency inverter, start view

1	Bluetooth active, flashing during communication
2	Motor running
3	Motor stopped
4	Stand-by
5	Read value
6	Measurement unit
7	Alarm
8	Warning

Table 13: Parameterisation

Parameterisation	Description
XX.X [bar]	Measured pressure value
XXX.X [Hz]	Frequency the inverter drives the motor with
XXX [VAC]	Supply voltage of the inverter. This only occurs when the motor is OFF. In ON condition the current input of the motor is shown instead of the supply voltage.
XX.X [A]	Current input of the motor
X.XX [cos ϕ]	Cosine of phase offset ϕ between voltage and current, also referred to as motor power factor
XX.X [kW]	Estimated effective power absorbed by the motor.
X [INV]	Device address if Combo functionality is activated.
AXX	Alarm XX
WXX	Warning XX

7.2 Pressure booster systems with configured frequency inverter drives

Drives supplied as part of the pressure booster system are already configured for operation. The information on default settings is provided for information only; it is only required if the drive needs replacing.

Table 14: Nastec Mida VFD technical data

Model	V_{in}	Maximum V_{out}	Maximum I_{in}	Maximum I_{out}	Motor power P_2
	[VAC]	[V]	[A]	[A]	[kW]
MIDA 203	1~230 +/-15 %	3~230	5	3	0,55
MIDA 205	1~230 +/-15 %	3~230	8	5	1,1
MIDA 207	1~230 +/-15 %	3~230	11	7,5	2,0
MIDA 404	3~380 - 460	$3 \times V_{in}$	3,7	4	1,1
MIDA 406	3~380 - 460	$3 \times V_{in}$	5,4	6	2,2
MIDA 409	3~380 - 460	$3 \times V_{in}$	8	9	4

7.3 Programming

The signal LED lights up in red when the pressure booster system is energised.









Press the Start/stop button  to start up the pump. When the selected setpoint has been reached, the signal LED lights up continuously in green.

Press the Start/stop button  to stop the pump. The signal LED changes from green to red (stand-by status).

Adjusting the pressure







A pressure gauge is fitted in the discharge line. Slightly opening one of the consumer installations facilitates pressure adjustment.

Adjusting the pressure

1. Press the Start/stop button  .
⇒ The pump starts up.
2. **When the Start/stop button lock function is activated:** Press the Start/stop button  for at least 5 seconds.
3. When the Start/stop button lock function is activated, the buttons  and  serve to scroll through the operating parameters for the pressure.
4. To be able to adjust the pressure press the  or  button for more than 5 seconds until the setting value to be changed starts flashing.
5. Press the  or  button to adjust the pressure.
6. **Confirm the set value:** Wait for 5 seconds or press the Start/stop button  .

8 Servicing/Maintenance

8.1 General information/Safety regulations

	<p>⚠ DANGER Unintentional start-up of pressure booster system Danger to life!</p> <ul style="list-style-type: none">▸ De-energise the pressure booster system for any repair work or servicing work.▸ Ensure that the pressure booster system cannot be re-energised unintentionally.
	<p>⚠ DANGER Voltage at the pressure booster system Danger to life!</p> <ul style="list-style-type: none">▸ Prior to opening the device, wait at least 10 minutes for any residual voltage to dissipate.
	<p>⚠ WARNING Improper lifting/moving of heavy assemblies or components Personal injury and damage to property!</p> <ul style="list-style-type: none">▸ Use suitable transport devices, lifting equipment and lifting tackle to move heavy assemblies or components.
	<p>⚠ WARNING Unintentional start-up of pressure booster system Risk of injury by moving parts!</p> <ul style="list-style-type: none">▸ Make sure the pressure booster system has been de-energised before commencing work on the pressure booster system.▸ Make sure that the pressure booster system cannot be started up unintentionally.
	<p>⚠ WARNING Unqualified personnel performing work on the pressure booster system Risk of personal injury!</p> <ul style="list-style-type: none">▸ Always have repair and maintenance work performed by specially trained, qualified personnel.
	<p>CAUTION Incorrectly serviced pressure booster system Function of pressure booster system not guaranteed!</p> <ul style="list-style-type: none">▸ Regularly service the pressure booster system.▸ Prepare a maintenance schedule for the pressure booster system, with special emphasis on lubricants, shaft seals and pump couplings.

The operator ensures that maintenance, inspection and installation are performed by authorised, qualified specialist personnel who are thoroughly familiar with the manual.

- Observe the safety instructions and information.
- For any work on the pump (set) observe the operating manual of the pump (set).
- In the event of damage you can always contact Duijvelaar Pompen B.V. Service.
- A regular maintenance schedule will help avoid expensive repairs and contribute to trouble-free, reliable operation with a minimum of maintenance expenditure and work.
- Never use force when dismantling and reassembling the equipment.

8.1.1 Inspection contract

For inspection work and servicing work we recommend the Duijvelaar Pompen B.V. inspection contract. Contact your service partner for details.

8.2 Servicing/inspection

8.2.1 Supervision of operation



CAUTION
Increased wear due to dry running
 Damage to the pump set!

- ▷ Never operate the pump set without liquid fill.
- ▷ Never close the shut-off element in the suction line and/or supply line during pump operation.



CAUTION
Impermissibly high temperature of fluid handled
 Damage to the pump!

- ▷ Prolonged operation against a closed shut-off element is not permitted (heating up of the fluid).
- ▷ Observe the temperature limits in the data sheet and in the section on operating limits.

While the pump is in operation, observe and check the following:

- If activated, check the functional check run.
- Measure the actual start-up pressure and stop pressure of the pump sets with a pressure gauge. Compare the values with the specifications on the name plate.
- Compare the pre-charge pressure of the accumulator with the recommended data. [⇒ Section 8.2.3, Page 38]
- Check the rolling element bearings for running noises.
 Vibrations, noise and an increase in current input occurring during unchanged operating conditions indicate wear.
- Monitor the functions of auxiliary connections, if any.

8.2.2 Maintenance schedule

Table 15: Overview of maintenance work

Maintenance interval	Servicing/maintenance work
At least once a year	Check the pump sets for smooth running and the mechanical seal for integrity.
	Check the shut-off elements, drain valves and check valves for proper functioning and tightness.

Maintenance interval	Servicing/maintenance work
	If fitted, clean the strainer in the pressure reducer.
	If fitted, check the expansion joints for any wear.
	Verify the pre-charge pressure. Check the accumulator for integrity. [⇒ Section 8.2.3, Page 38]
	Check the automatic switching functionality.
	Check the cut-in levels and cut-out levels.
	Check the inflow, inlet pressure, dry running protection, flow monitoring and pressure reducer.

8.2.3 Setting the pre-charge pressure



WARNING

Wrong gas

Danger of poisoning!

- ▷ Use only nitrogen as cushion gas of the membrane-type accumulator.



CAUTION

Pre-charge pressure too high

Damage to the accumulator!

- ▷ Observe the manufacturer's product literature (see name plate or operating manual of the accumulator).

The accumulator's pre-charge pressure (p) must be lower than the set start-up pressure (p_E) of the pressure booster system.

The best storage volumes are achieved with the following settings (mean value):

- Value 0.9 at start-up pressure > 3 bar
- Value 0.8 at start-up pressure < 3 bar

Example 1 $p_E = 5$ bar

$$5 \text{ bar} \times 0.9 = 4.5 \text{ bar}$$

With a start-up pressure of 5 bar the pre-charge pressure of the accumulator must be 4.5 bar.

Example 2 $p_E = 2$ bar

$$2 \text{ bar} \times 0.8 = 1.6 \text{ bar}$$

With a start-up pressure of 2 bar the pre-charge pressure of the accumulator must be 1.6 bar.

Checking the pre-charge pressure

1. Close the shut-off elements fitted underneath the membrane-type accumulator.
2. Drain the membrane-type accumulator via the drain valve.
3. Remove and store the protective cap of the membrane-type accumulator valve.
4. Check the pre-charge pressure using suitable equipment (e.g. tyre pressure gauge).
5. Fit the protective cap of the membrane-type accumulator valve.

Filling the membrane-type accumulator

1. Remove and store the protective cap of the membrane-type accumulator valve.
2. Add nitrogen through the valve.
3. Fit the protective cap of the membrane-type accumulator valve.

8.2.4 Replacing the non-return valve



⚠ DANGER

Voltage at the pressure booster system

Danger to life!

- Prior to opening the device, wait at least 10 minutes for any residual voltage to dissipate.

1. De-energise the pump set and secure it against unintentional start-up. Comply with the local regulations.
2. Close the shut-off valve of the pump.
3. Place a suitable container under the drain connection.
4. Open the drain connections. To do so, observe the pump's operating manual.

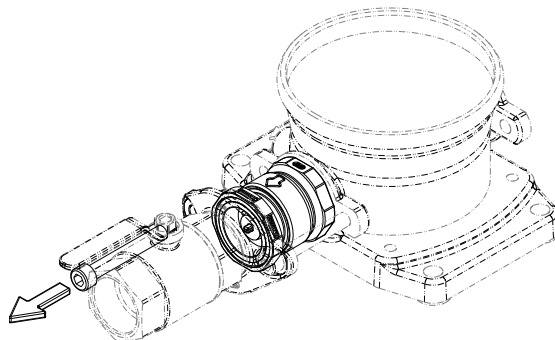

Fig. 13: Removing the screw

5. Remove the screw.

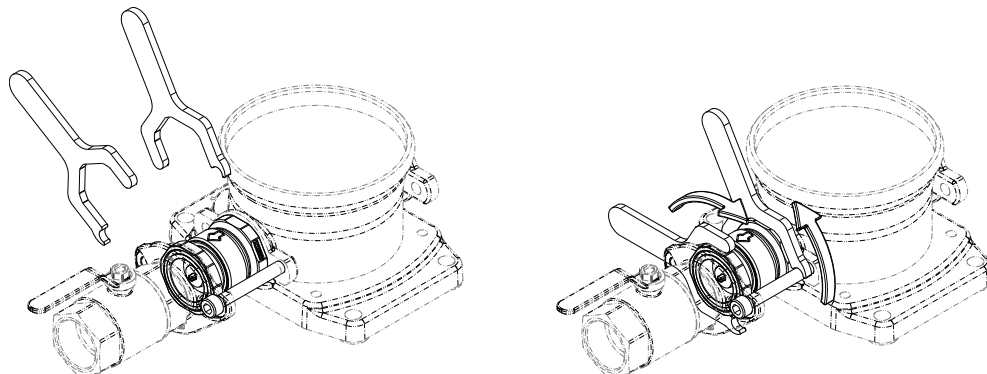

Fig. 14: Screwing the valve's body parts into each other

6. Use a suitable tool to screw the body parts of the non-return valve into each other to shorten the length of the body.

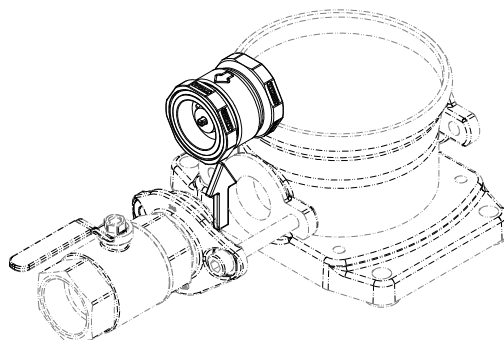

Fig. 15: Removing the body

7. Remove the body of the non-return valve.

8. Remove the insert check valve including O-rings.
9. Remove excessive contamination or deposits with a clean cloth.
10. Re-insert the insert check valve into the body. Apply lubricant to new O-rings. See table below.

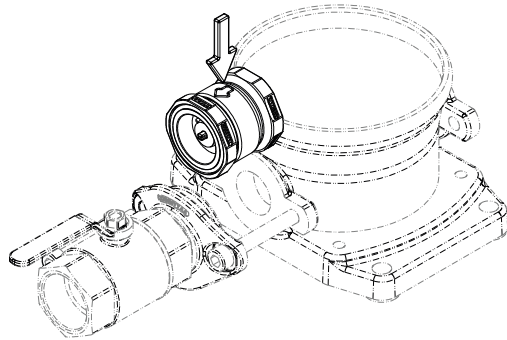

Fig. 16: Mounting the body

11. Mount the body of the non-return valve.

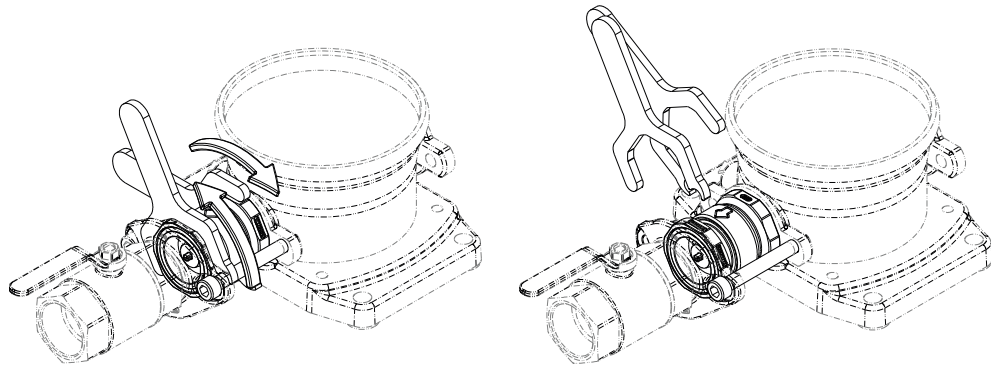

Fig. 17: Loosening the screwed connection of the body parts

12. Use a suitable tool to loosen the screwed connection of the body parts of the non-return valve to extend the body length.



Fig. 18: Verifying the alignment

13. Verify the correct alignment.

40 / 52

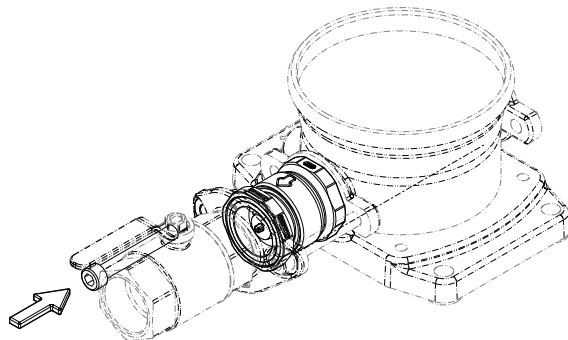

Fig. 19: Fitting the screw

14. Fit and tighten the screw.

15. Close the drain plugs of the pump. Properly dispose of the fluid collected.
16. Slowly open the shut-off valve and check for any leakage.

Table 16: Spare parts for servicing non-return valves, per pump

Material number	Description	Non-return valve	O-rings	O-ring lubricant (non-water soluble)
71630405	ER non-return valve DN 32	Watts Industries IN 032 DN 32	1x Eriks 12711456	Molykote® G-5511 ³⁾
			2x Eriks 12711457	
71630410	ER non-return valve DN 50	Watts Industries IN 050 DN 50	1x Eriks 12192264	
			2x Eriks 12711459	

³⁾ Sealant for taps



9 Trouble-shooting



NOTE

Please contact Duijvelaar Pompen B.V. Service before carrying out any work on the pump's internal parts during the warranty period. Non-compliance will lead to forfeiture of warranty cover and of any and all rights to claims for damages.

Table 17: Pump faults

Fault	Possible cause	Remedy	Action
Leakage along the shaft	Worn shaft seal	Replace the shaft seal.	Check the pump for impurities.
	Pump has been operated without water.	Replace the shaft seal.	
Pump does not run smoothly (noise and vibrations).	No water in the pump		Prime and vent the pump.
	No water supply	Re-establish water supply.	Check supply lines for clogging.
	Bearings of pump and/or motor defective	Have bearings replaced by certified company.	
	Hydraulic pump components defective	Replace hydraulic pump components.	
	Wrong direction of rotation of the pump	Interchange two phases of the power supply between frequency inverter and motor. Caution: Prior to opening the device, wait at least 10 minutes for any residual voltage to dissipate.	
System/pump does not start.	No voltage at the terminals	Check power supply.	
	Dry running protection has tripped.	Re-establish water supply. Reset system.	Check that the supply tank is filled with water and that the supply line to the pressure booster system is not clogged.
	Wrong setting of pressure setpoint	Adjust pressure setpoint.	
	Drive fault	Reset drive and note down error code.	
Insufficient flow rate and/or pressure of the system/pump	Air inside the pump	Vent the pump.	
	Wrong direction of rotation of the pump	Interchange two phases of the power supply between frequency inverter and motor. Caution: Prior to opening the device, wait at least 10 minutes for any residual voltage to dissipate.	
	Flow rate of water meter in suction line too low	Increase flow rate of water meter.	
	System-side filter clogged	Clean filter or check filter for obstruction. If required, replace filter.	
	Shut-off valve in outlet and/or inlet closed	Open both shut-off valves.	
	Pumps start and stop too frequently.	Accumulator leakage or wrong pressure setting	
Pump 1 not running, pump 2 running.	Pump 1 has been stopped, and pump 2 has assumed the master function.	Disconnect the system from the power supply. Then reconnect it.	

The yellow alarm LED indicates different alarm messages by flashing at different frequencies followed by a 3-second pause.

Table 18: Error codes of the frequency inverter

Flashing frequency	Description	System re-start
1x	Lack of water. Automatic re-start after 5-10-20-40-80 minutes. The alarm signal starts after the last re-start attempt.	De-energise the system (pull the mains plug or set the master switch to 0). Only after the system has been de-energised can it be re-started.
2x	The maximum motor current is higher than the set limit.	
3x	Sensor alarm (sensor not connected or incorrectly connected, or output current below 2 mA)	
4x	Overheating alarm (temperature at NTC thermistor exceeds 70 °C)	
5x	Frequency inverter alarm (current too high)	De-energise the system (pull the mains plug or set the master switch to 0). Only after the system has been de-energised can it be re-started.
6x	Communication error between master and slaves (check the DIP switch position). Caution: After switching off the frequency inverter, wait 10 minutes until dangerous voltages have discharged.	
7x	The alarm value for the maximum pressure has been reached. (Determine the cause of the maximum pressure exceeding the alarm value).	
8x	The alarm value for minimum pressure has been reached. (Determine the cause of the minimum pressure falling below the alarm value).	
Rapid flashing without any pauses	The digital inputs have been disconnected.	

10 Related Documents

10.1 General assembly drawings/exploded views with list of components

10.1.1 Hydro-Unit Single Line MVP

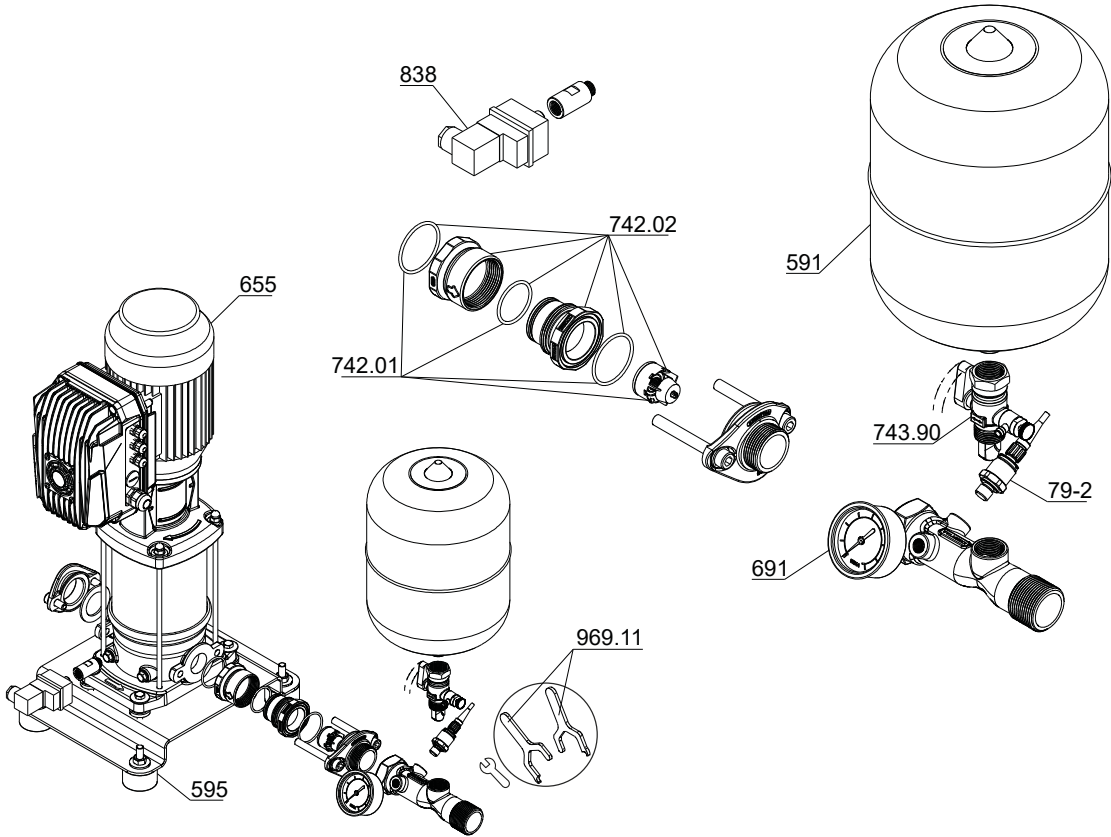

Fig. 20: Single Line MVP

Table 19: List of components

Part No.	Description	Part No.	Description
79-2	Measuring transducer	742.01.02	Lift check valve
591	Membrane-type accumulator	743.90	Ball valve
595	Anti-vibration pad	838	Pressure switch
655	Pump	969.11	Tool
691	Pressure gauge		

The individual parts of the pump set are shown in the product literature of the pump set.

11 EU Declaration of Conformity

Manufacturer:

**Duijvelaar Pompen
DP Pumps
Kalkovenweg 13**

2401 LJ Alphen aan den Rijn (The Netherlands)

This EU Declaration of Conformity is issued under the sole responsibility of the manufacturer.

The manufacturer herewith declares that **the product**:

Hydro-Unit Single Line MVP

Type code: 38/2019 0000000-0001 - 52/2021 9999999-9999

- is in conformity with the provisions of the following directives / regulations as amended from time to time:
 - Pump set: 2006/42/EC Machinery Directive
 - Electrical components: 2011/65/EU Restriction of the Use of Certain Hazardous Substances in Electrical and Electronic Equipment (RoHS)
 - 2014/30/EU: Electromagnetic Compatibility (EMC)

The manufacturer also declares that

- the following harmonised international standards have been applied:
 - ISO 12100
 - EN 809
 - EN 60204-1
 - EN 806-2

Person authorised to compile the technical file:

Ron Bijman
Manager Competence Centre Products
Duijvelaar Pompen B.V.
Kalkovenweg 13
2401 LJ Alphen aan den Rijn (The Netherlands)

The EU Declaration of Conformity was issued in/on:

Alphen aan den Rijn, 1 July 2022



Ron Bijman
Manager Competence Centre Products
Duijvelaar Pompen B.V.
Kalkovenweg 13
2401 LJ Alphen aan den Rijn (The Netherlands)

12 Certificate of Decontamination

Type:

Order number /

Order item number⁴⁾:

Delivery date:

Application:

Fluid handled⁴⁾:

Please tick where applicable⁴⁾:



Corrosive



Oxidising



Flammable



Explosive



Hazardous to health



Seriously hazardous to health



Toxic



Radioactive



Bio-hazardous



Safe

Reason for return⁴⁾:

Comments:

The product / accessories have been carefully drained, cleaned and decontaminated inside and outside prior to dispatch / placing at your disposal.

We herewith declare that this product is free from hazardous chemicals and biological and radioactive substances.

For mag-drive pumps, the inner rotor unit (impeller, casing cover, bearing ring carrier, plain bearing, inner rotor) has been removed from the pump and cleaned. In cases of containment shroud leakage, the outer rotor, bearing bracket lantern, leakage barrier and bearing bracket or intermediate piece have also been cleaned.

For canned motor pumps, the rotor and plain bearing have been removed from the pump for cleaning. In cases of leakage at the stator can, the stator space has been examined for fluid leakage; if fluid handled has penetrated the stator space, it has been removed.

- No special safety precautions are required for further handling.
- The following safety precautions are required for flushing fluids, fluid residues and disposal:

.....

.....

46 / 52

We confirm that the above data and information are correct and complete and that dispatch is effected in accordance with the relevant legal provisions.

.....
Place, date and signature

.....
Address

.....
Company stamp

⁴ Required field

13 Commissioning Report

The pressure booster system specified below has been commissioned today by the undersigned, authorised Duijvelaar Pompen B.V. Service who created this report.

Pressure booster system details

Type series
Size
Serial number
Order No.

Purchaser/place of installation

Purchaser	Place of installation
Name
Address
.....

Operating data

For further data refer to the wiring diagram.

Start-up pressure p_E bar
Inlet pressure monitoring $p_{inl} - x$
(setting of inlet pressure switch)
Stop pressure p_A bar
Inlet pressure p_{inl} [bar]
Pre-charge pressure
of accumulator $p_{pre-charge}$
[bar]

The operator or operator's representative herewith confirms to have received instructions on how to operate and service the pressure booster system. The relevant circuit diagrams and operating instructions have been handed over.

Non-conformities found during commissioning	Deadline for remedial action
Non-conformity 1.....
.....
.....
.....

Name of Duijvelaar Pompen B.V. representative	Name of purchaser or representative
.....
Place	Date
.....



Index

C

Certificate of Decontamination	46
Commissioning/start-up	27

D

Designation	15
Disposal	14
Drive	16
Dry running protection	27
Connecting the dry running protection device	25

E

EMC Directive	10
Event of damage	6

I

Installation	16
Installation at site	22
Intended use	8
Interference emissions	10

K

Key to safety symbols/markings	7
--------------------------------	---

M

Maintenance work	37
------------------	----

O

Operating limits	8
Other applicable documents	6

P

Partly completed machinery	6
Personnel	9
Preservation	13

Q

48 / 52 Qualification	9
-----------------------	---

R

Return to supplier	14
--------------------	----

S

Safety	8
Safety awareness	9
Scope of supply	17
Storage	13

W

Warnings	7
Warranty claims	6

duijvelaar pompen
dp pumps

Kalkovenweg 13
2401 LJ Alphen aan den Rijn (NL)

☎ +31 72 48 83 88

www.dp.nl

2025-06-30

BE00001182 (1983.8341/05-EN)

